

# IRmadillo™ FTIR Spectrometer Technical Specifications



## A Rugged FTIR Spectrometer

Keit developed a rugged Fourier Transform Infrared (FTIR) spectrometer designed to take on the rigours of the manufacturing environment with simple, fixed components. Extremely stable, and low maintenance, the IRmadillo™ mid-infrared spectrometer is easy-to-use for real-time process monitoring of liquids and slurries both indoors and outside.

### Key Advantages

- Compact
- No moving parts
- Vibration tolerant
- Long-term stability

### Primary Benefits

- Real-time reaction analysis - no need for remote sampling or long waiting times for laboratory results to be returned
- Use almost anywhere in difficult environments - indoors or outside
- Simple to use, requires minimal training, less worry
- Low maintenance, low power for reduced overhead on your analytical instrumentation
- Provides greater insight into your manufacturing processes for improved quality control

### Industrial Applications - PAT

The novel optical design of the Keit IRmadillo FTIR spectrometer is an innovation in Process Analytical Technology (PAT). It allows for real-time chemical reaction monitoring of industrial processes at the point of production. Manufacturers can harness the power of FTIR for more efficient measurements and improved quality control.

### Industries

- Chemical
- Pharmaceutical
- Bio-renewables
- Oil & Gas
- Food & Beverage
- Polymers & Plastics

### Main Features

- Long lifetime light emitter
- Tough instrument for industrial environments with ATEX & IECEx certification
- Choice of ATR and dip probe materials compatible for a wide range of operating environments
- No moving parts resulting in extreme vibration tolerance
- Fixed dip probe with no need for long fibre-optic cables to connect probe to your reaction
- Output compatible with all major chemometric analysis packages
- Mid-infrared spectrum analysis with easy to download data file formats
- Stable instrument with recalibration frequency minimal to none

### Principle of Operations

FTIR spectroscopy enables material identification by measuring the amount of light in the mid-infrared region absorbed at the molecular level. Standard instruments contain delicate moving parts and rely on fragile fibre-optic interconnectors making it impractical to use in production environments. Our novel design has no moving parts. The rigid probe is inserted directly into reaction vessels (or process lines) for immediate analysis. The IRmadillo's extreme vibration tolerance eliminates the need for long fibre-optic cables between the probe and the spectrometer, thereby reducing cost while improving performance and reliability.

### Process Monitoring Benefits

The IRmadillo FTIR spectrometer works effectively to monitor both batch and in-line manufacturing processes in harsh production environments where standard instruments struggle to operate. Our instrument helps chemical engineering and production staff make process-optimising decisions in real time using the power of FTIR spectroscopy.

# IRmadillo™ FTIR Spectrometer Technical Specifications

Model Number: ASM0627

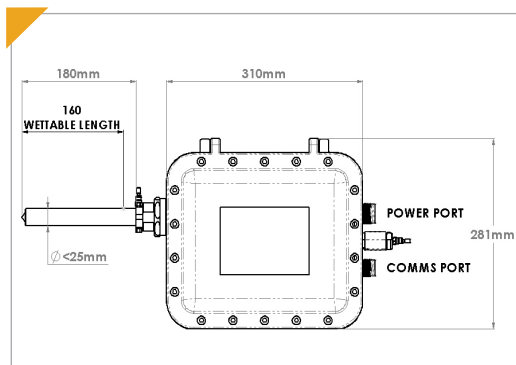

**Diagram 1:** Top view looking down, showing exterior casing with insertion probe and external port positions.

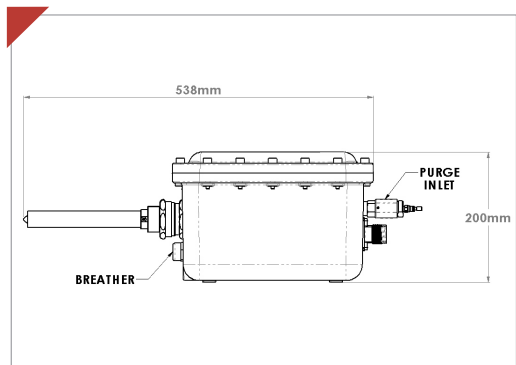

**Diagram 2:** Side view, exterior. The inherent structural simplicity results in a uniquely rugged, compact device.

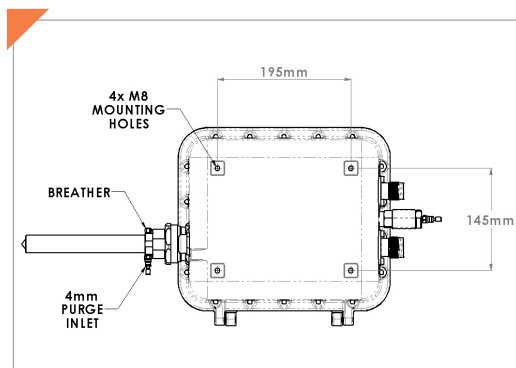

**Diagram 3:** Bottom view, exterior - looking up showing position of mounting holes.

Parameter	IRmadillo™ Rugged FTIR Spectrometer
Spectral range	Mid-Infrared (850-4000 cm <sup>-1</sup> /2.5-12 μm)
Sampling material environment	Liquids and slurries
Sample interface	ATR Insertion probe
ATR & probe material	ATR: Infrared transparent glass (chalcogenide) Probe: Hastelloy or stainless steel
Operating environment	Ambient temperature: -15°C to +40°C (5°F to 104°F) Analyte temperature: -15°C to +80°C (5°F to 176°F): process dependent Ambient humidity: 0-95% RH Analyte Pressure: 1 to 20 bar (absolute) pH range: 0 to 9 (process dependent)
Enclosure rating	IP65
Long-term stability	±0.01 absorbance units between calibration intervals. Fixed interior components ensure high stability and vibration tolerance.
Sensitivity	LoD 100 ppm (typical)
Minimum acquisition time	2 s
Signal to noise ratio (SNR)	Peak SNR 15500 (2 min sampling time)
Dimensions	Body (H x W x D): 200 x 281 x 310 mm (approx. 8 x 11 x 12 in) Insertion Probe: Maximum wettable length: 160 mm (6.3 in) Diameter: 25 mm (approx. 1 in)
Weight	Approx. 18.5 kg (40.8 lb)
Fibre-optic coupling	None. Instrument's fixed probe is inserted directly into reaction vessel.
Power & input requirements	Power: 100-240 Vac, 50/60 Hz, 100Wmax Purge gas (optional): Zero / instrument grade air or N <sub>2</sub>
System cleaning process compatibility	Sterilise in place (SIP): Process dependent Clean in place (CIP): No
Data output	OPC-UA Modbus Export as text file (e.g., CSV) Compatible with all major analysis packages
Hazardous environment certification	 II 2G Ex db IIB+H <sub>2</sub> T4 Ga/Gb IECEX BAS 17.0030X Baseefa17ATEX0037X

DOC0354R 18 June 2019 15:11



©2019 Keit Ltd. trading as Keit Spectrometers  
4 Zephyr Building, Eighth Street, Harwell Campus, Didcot, Oxfordshire, OX11 0RL, United Kingdom  
+44 (0) 1235 431260 ■ enquiries@keit.co.uk ■ www.keit.co.uk

IRmadillo is a Registered Trademark in the US under 5389749, in the UK under 3185204, and at the EUIPO under 016222408.  
KEIT is a Registered Trademark at the EUIPO under 012140414.